

RTBH Series

1-2 Pole Coded Rotary Switches



Features/Benefits

- **Totally sealed**
- **Detent angles, 15 , 22.5 , 30 and 36**
- **Multi pole**
- **Coding functions**
- **Robust construction**
- **RoHS Compliant**

Typical Applications

- **Telecommunications**
- **Military**
- **Instrumentation**
- **Heavy-duty industrial equipment**

Electrical Data

	Silver	Gold
SWITCHING MODE:	BBM*	BBM*
MAX. SWITCHING POWER:	5VA	0.2VA
Max. SWITCHING CURRENT:	250 mA	20 mA
MIN. SWITCHING CURRENT:	10 mA	1 mA
MAX. CARRYING CURRENT:	5A	1A
MAX. VOLTAGE:	25V	25V
MIN. VOLTAGE:	5V	1V
BOUNCE:	<5ms	<5ms
CONTACT RESISTANCE after life:	<100mΩ	<100mΩ
DIELECTRIC STRENGTH between contacts or contacts and frame:	500 V rms	500 V rms
INSULATION RESISTANCE between contacts or contacts and frame:	>10 ⁹ Ω	>10 ⁹ Ω

Mechanical Data

NUMBER OF BANKS:	1 to 4
OPERATING TORQUE:	5 Ncm±30% (with 1 module)
MECHANICAL STOP RESISTANCE:	>70 Ncm
BUSHING MOUNTING TORQUE:	100 Ncm

Environmental Data

OPERATING TEMPERATURE:	-25°C to +70°C
STORAGE TEMPERATURE:	-40°C to +85°C
TOTALLY SEALED:	Immersion test acc. to MIL R22.097 F and NFC 20631/QF

* BBM= Break Before Make (non-starting)

Materials

HOUSING: PBT thermoplastic and PC thermoplastic
 STATIONARY CONTACTS & TERMINALS: Nickel plated Brass with additional Gold or Silver plating, insert molded in PBT thermoplastic.
 ROTOR: Printed circuit, gold or silver plated.
 ACTUATOR: Steel
 BUSHING: Brass
 HARDWARE: Stop pin and spring: Stainless steel
 All models are RoHS compliant and compatible.

NOTE: Specifications and materials listed above are for switches with standard options. For information on specific and custom switches, consult Customer Service Center.

Build-A-Switch

To order, simply select desired option from each category and place in the appropriate box. Available options are shown and described on pages L-23 thru L-27. For additional options not shown in catalog, consult Customer Service Center.



Designation

RTBH

Indexing

- 1 15°/24 positions max.
- 2 22.5°/16 positions max.
- 3 30°/12 positions max.
- 4 36°/10 positions max.

Number of Banks**

- 1 1 Bank
- 2 2 Banks
- 3 3 Banks
- 4 4 Banks

Switch Function Number of Poles or code (binary code = B, complement = C, direct +complement = BC) (first digit), Stop (with=S, without=W), Maximum Position (third & fourth digit)

1S02	SP, 02 positions with stop	
1S03	SP, 03 positions with stop	
1S04	SP, 04 positions with stop	
1S05	SP, 05 positions with stop	
1S06	SP, 06 positions with stop	
1S07	SP, 07 positions with stop	
1S10	SP, 10 positions with stop	1W16 SP, 16 positions without stop
1W10	SP, 10 positions without stop	1S24 SP, 24 positions with stop
1S11	SP, 11 positions with stop	1W24 SP, 24 positions without stop
1S12	SP, 12 positions with stop	2S04 DP, 4 positions with stop
1W12	SP, 12 positions without stop	2S05 DP, 5 positions with stop
1S14	SP, 14 positions with stop	2S06 DP, 6 positions with stop
1S16	SP, 16 positions with stop	GS__ Gray Code with stop (indicate position)

Contact Material

- S** Silver plated, matte-tin terminal
- P** Gold plated, matte-tin terminal

Actuator Length

- Z** (.984) 25 mm

Actuator Option Angle*

- N** None for actuators without a flat
- 0** 0° angle
- 3** 30° angle
- 6** 60° angle
- 9** 90° angle
- 2** 120° angle
- 8** 180° angle
- 7** 270° angle

Shaft Diameter & Style***

- N** Metric shaft .236 (6,0)
- P** Standard shaft .250 (6,35)
- F** Metric shaft with flat .236 (6,0)
- G** Standard shaft with flat .250 (6,35)
- S** Metric shaft with slot .236 (6,0)
- T** Standard shaft with slot .250 (6,35)

Seal

- A** Standard bushing for panel mount
- D** Sealed bushing for panel mount

- GW__** Gray Code without stop (indicate position) only can be 10,12, 16, 24 based on indexing
- BS__** Binary Code with stop (indicate position)
- BW__** Binary Code without stop (indicate position) only can be 10,12, 16, 24 based on indexing
- CW__** Complement with stop (indicate position)
- CW__** Complement without stop (indicate position) only can be 10,12, 16, 24 based on indexing
- ES__** Direct+Complement with stop (indicate position)
- EW__** Direct+Complement without stop (indicate position) only can be 10,12, 16, 24 based on indexing

* Other angles available by request

** Several functions can be combined. For more information consult us.

***Note: Metric diameter shafts are only available with metric diameter bushings, standard 1.250 inch diameter shafts are only available with standard 3/8 diameter bushings.

NOTE: S&T Shaft Diameter and Style are only available with Actuator Option angle 0, 6, 9, 2.



Dimensions are shown: Inch (mm)
 Specifications and dimensions subject to change

RTBH Series 1-2 Pole Coded Rotary Switches

DESIGNATION

RTBH

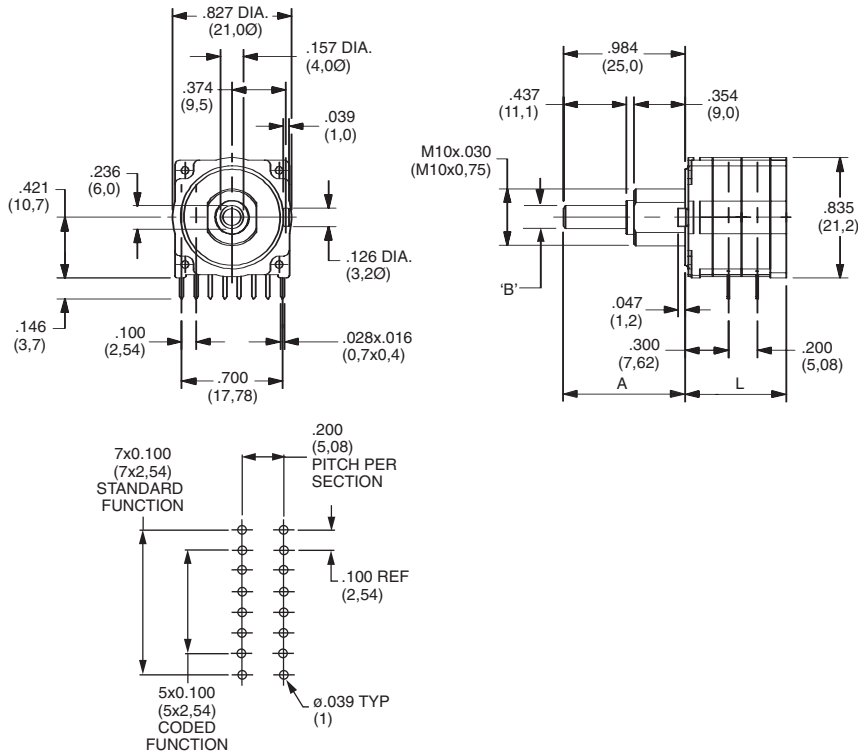

Dimensions L		
Number modules	inch	L mm
1	0.500	12.7
2	0.700	17.78
3	0.900	22.86
4	1.10	27.94

Dimensions A	
A: (standard) 0.984 inch (25 mm)	

Dimensions B	
0.236 or 0.250 inch (Ø6 or 6.35 mm)	

INDEXING

- 1** 15° index/24 positions
- 2** 22.5° index/16 positions
- 3** 30° index/12 positions
- 4** 36° index/10 positions

NUMBER OF BANKS

- 1** 1 BANK
- 2** 2 BANKS
- 3** 3 BANKS
- 4** 4 BANKS

NOTE: Several functions can be combined. For more information consult customer service.

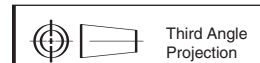

Dimensions are shown: Inch (mm)
Specifications and dimensions subject to change

RTBH Series

1-2 Pole Coded Rotary Switches

SWITCH FUNCTION

Switch Function Number of Poles or code (binary code = B, complement = C, direct +complement = BC)
 (first digit), Stop (with=S, without=W), Maximum Position (third & fourth digit)

- 1S02** SP, 02 positions with stop
 - 1S03** SP, 03 positions with stop
 - 1S04** SP, 04 positions with stop
 - 1S05** SP, 05 positions with stop
 - 1S06** SP, 06 positions with stop
 - 1S07** SP, 07 positions with stop
 - 1S10** SP, 10 positions with stop
 - 1W10** SP, 10 positions without stop
 - 1S11** SP, 11 positions with stop
 - 1S12** SP, 12 positions with stop
 - 1W12** SP, 12 positions without stop
 - 1S14** SP, 14 positions with stop
 - 1S16** SP, 16 positions with stop
 - 1W16** SP, 16 positions without stop
 - 1S24** SP, 24 positions with stop
 - 1W24** SP, 24 positions without stop
- 2S04** DP, 4 positions with stop
 - 2S05** DP, 5 positions with stop
 - 2S06** DP, 6 positions with stop
 - GS__** Gray Code with stop (indicate position)
 - GW__** Gray Code without stop (indicate position) only can be 10,12, 16, 24 based on indexing
 - BS__** Binary Code with stop (indicate position)
 - BW__** Binary Code without stop (indicate position) only can be 10,12, 16, 24 based on indexing
 - CS__** Complement with stop (indicate position)
 - CW__** Complement without stop (indicate position) only can be 10,12, 16, 24 based on indexing
 - ES__** Direct+Complement with stop (indicate position)
 - EW__** Direct+Complement without stop (indicate position) only can be 10,12, 16, 24 based on indexing

1 Single Pole Function 1S10, 1S12, 1S16, 1S24

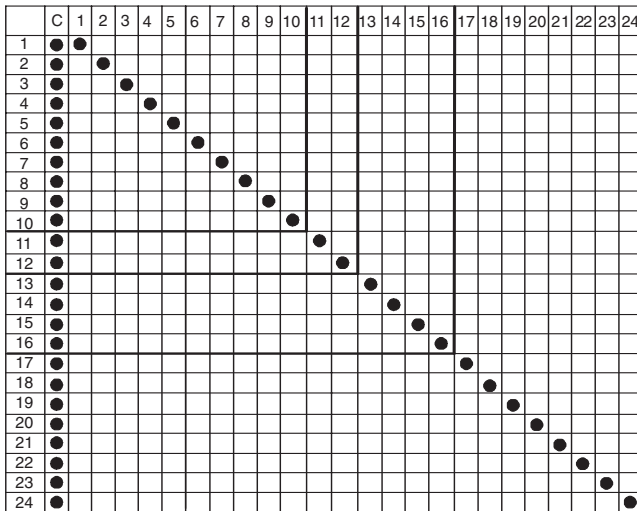

Rotary

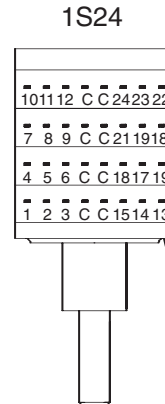
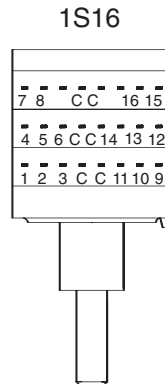
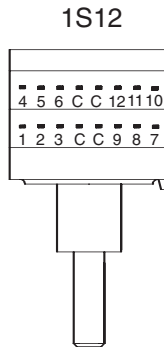
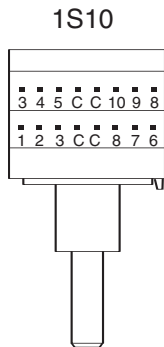

NOTE: Switch depicted from top down onto PCB.

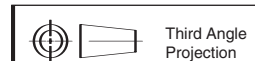

Dimensions are shown: Inch (mm)
 Specifications and dimensions subject to change

RTBH Series 1-2 Pole Coded Rotary Switches

SWITCH FUNCTION

2 DOUBLE POLE FUNCTION

	C ₁	1 ₁	2 ₁	3 ₁	4 ₁	5 ₁	6 ₁	C ₂	1 ₂	2 ₂	3 ₂	4 ₂	5 ₂	6 ₂
1	●	●						●	●					
2	●		●					●		●				
3	●			●				●			●			
4	●				●			●				●		
5	●					●		●					●	
6	●						●	●						●

2S06

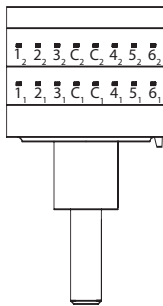

NOTE: Switch depicted from top down onto PCB.

B BINARY DIRECT CODE

	C	1	2	4	8	16
0	●					
1	●	●				
2	●		●			
3	●	●	●			
4	●			●		
5	●	●			●	
6	●	●	●			
7	●	●				
8	●				●	
9	●	●				●
10	●		●			
11	●	●	●			
12	●			●		
13	●	●				●
14	●	●	●			
15	●	●				
16	●					●
17	●	●				
18	●		●			
19	●	●				
20	●			●		
21	●	●				●
22	●	●	●			
23	●	●				

BS10 BS12 BS16

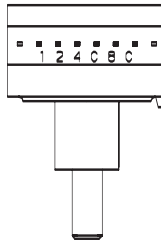

BS24

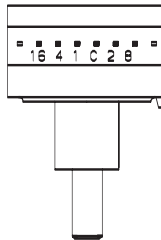

NOTE: Switch depicted from top down onto PCB.

C COMPLEMENT BINARY CODE

	C	1	2	4	8	16
0	●	●	●	●	●	●
1	●	●	●	●	●	●
2	●	●	●	●	●	●
3	●	●	●	●	●	●
4	●	●	●	●	●	●
5	●	●	●	●	●	●
6	●	●	●	●	●	●
7	●	●	●	●	●	●
8	●	●	●	●	●	●
9	●	●	●	●	●	●
10	●	●	●	●	●	●
11	●	●	●	●	●	●
12	●	●	●	●	●	●
13	●	●	●	●	●	●
14	●	●	●	●	●	●
15	●	●	●	●	●	●
16	●	●	●	●	●	●
17	●	●	●	●	●	●
18	●	●	●	●	●	●
19	●	●	●	●	●	●
20	●	●	●	●	●	●
21	●	●	●	●	●	●
22	●	●	●	●	●	●
23	●	●	●	●	●	●

CS10 CS12 CS16

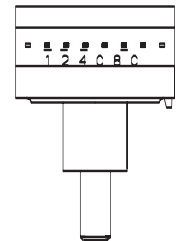

CS24

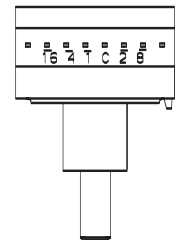

NOTE: Switch depicted from top down onto PCB.

G GRAY CODE

	C	1	2	3	4	5
1	●					
2	●	●				
3	●		●			
4	●	●	●			
5	●			●		
6	●	●	●	●		
7	●	●			●	
8	●			●		
9	●	●	●			●
10	●	●	●	●		
11	●	●			●	
12	●	●	●			
13	●			●		
14	●	●			●	
15	●			●		
16	●				●	
17	●	●				●
18	●	●	●			
19	●	●			●	
20	●	●	●			●
21	●	●			●	
22	●	●	●			●
23	●	●	●			●
24	●			●		

GS10 GS12 GS16

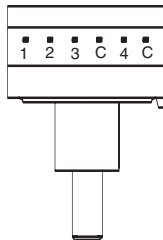

GS24

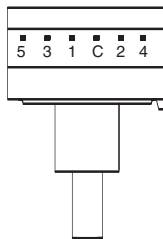

NOTE: Switch depicted from top down onto PCB.

E DIRECT AND COMPLEMENT BINARY CODE

	C	1	2	4	8	16	C	1	2	4	8	16
0	●						●	●	●	●	●	●
1	●	●					●	●	●	●	●	●
2	●		●				●	●	●	●	●	●
3	●	●	●				●	●	●	●	●	●
4	●			●			●	●	●	●	●	●
5	●	●			●		●	●	●	●	●	●
6	●	●	●				●	●	●	●	●	●
7	●	●					●	●	●	●	●	●
8	●			●			●	●	●	●	●	●
9	●	●					●	●	●	●	●	●
10	●	●	●				●	●	●	●	●	●
11	●	●					●	●	●	●	●	●
12	●			●			●	●	●	●	●	●
13	●	●					●	●	●	●	●	●
14	●	●	●				●	●	●	●	●	●
15	●	●					●	●	●	●	●	●
16	●					●	●	●	●	●	●	●
17	●	●					●	●	●	●	●	●
18	●		●				●	●	●	●	●	●
19	●	●					●	●	●	●	●	●
20	●	●	●				●	●	●	●	●	●
21	●	●					●	●	●	●	●	●
22	●	●	●				●	●	●	●	●	●
23	●	●					●	●	●	●	●	●

ES10 ES12 ES16

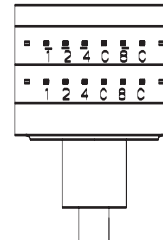

ES24

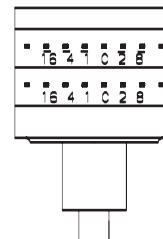

NOTE: Switch depicted from top down onto PCB.



RTBH Series 1-2 Pole Coded Rotary Switches

SEAL

A STANDARD BUSHING FOR PANEL MOUNT

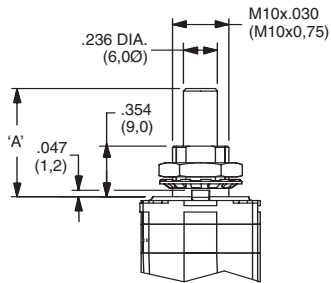

D SEALED BUSHING FOR PANEL MOUNT

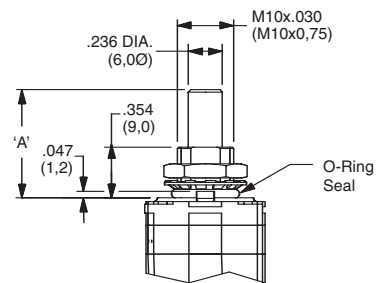

SHAFT DIAMETER & STYLE

N METRIC SHAFT 0.236 (6,0)

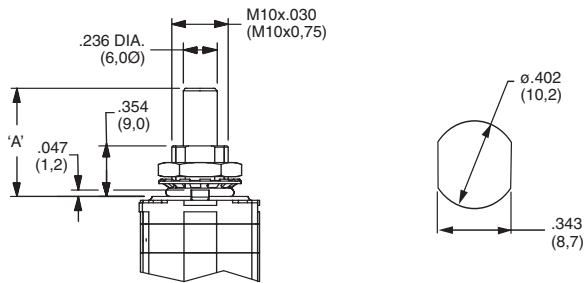

P STANDARD SHAFT 0.250 (6,35)

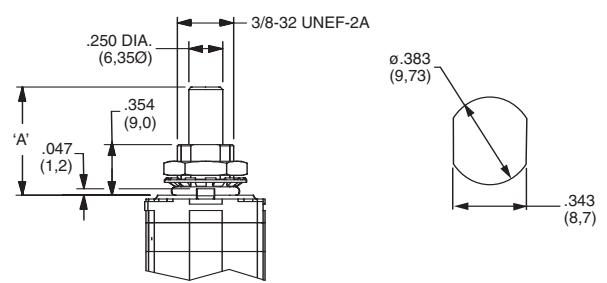

F METRIC SHAFT WITH FLAT 0.236 (6,0)

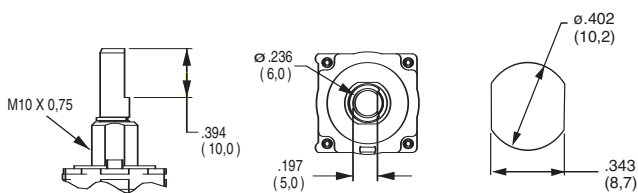

G STANDARD SHAFT WITH FLAT 0.250 (6,35)

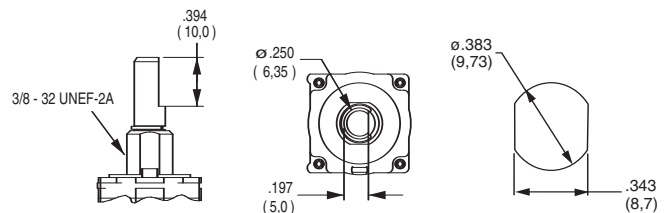

S METRIC SHAFT WITH SLOT 0.236 (6,0)

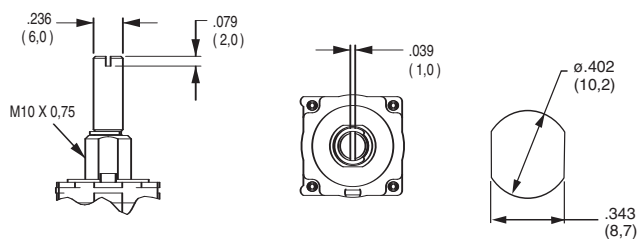

T STANDARD SHAFT WITH SLOT 0.250 (6,35)

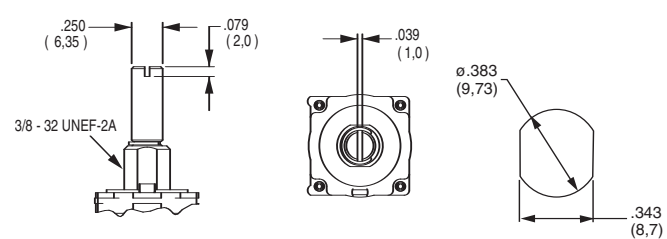

***Note: Metric diameter shafts are only available with metric diameter bushings, standard 1.250 inch diameter shafts are only available with standard 3/8 diameter bushings.



Third Angle
Projection

Dimensions are shown: Inch (mm)
Specifications and dimensions subject to change



Rotary

C&K RTBH Series 1-2 Pole Coded Rotary Switches

ACTUATOR OPTION ANGLE

SHAFT WITH FLAT OPTIONS

N (None) FOR ACTUATORS WITHOUT A FLAT

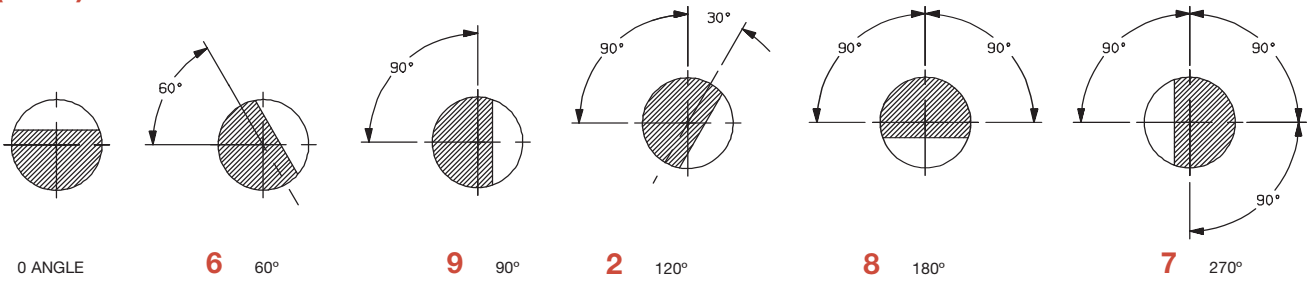

SHAFT WITH SLOT OPTIONS

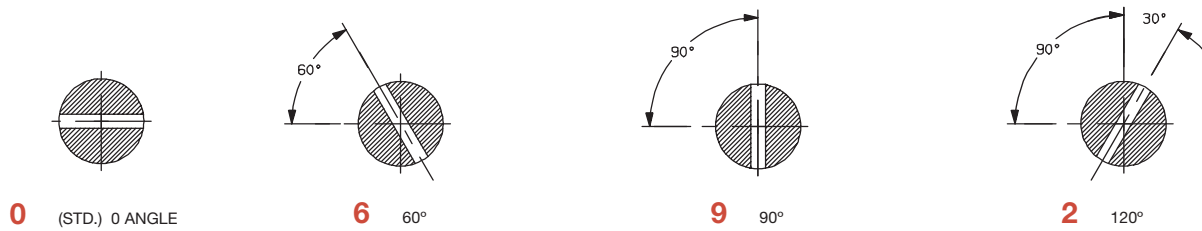

ACTUATOR LENGTH

Z (.984) 0,25 mm STANDARD SHAFT

Other lengths available by request.

CONTACT MATERIAL

OPTION CODE	CONTACT AND TERMINAL MATERIAL	RATING
S	SILVER	SWITCH: 250 mA, POWER: 5 VA; CARRY: 5 AMPS
P	GOLD	SWITCH: 20 mA, POWER: 0.2 VA; CARRY: 1 AMP

* Note: See Technical Data section of this catalog for RoHS compliant and compatible definition and specifications.

SWITCHING POWER

S (SILVER CONTACTS)

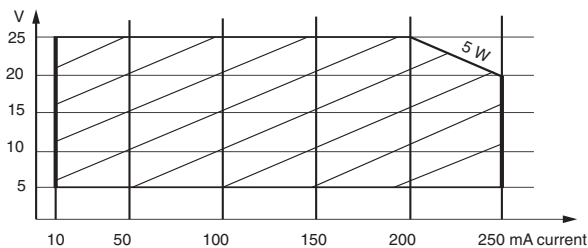

Switching power: 5 W
Max. voltage: 25 V
Min. voltage: 5 V
Max. switching current: 250 mA
Min. switching current: 10 mA

P (GOLD CONTACTS)

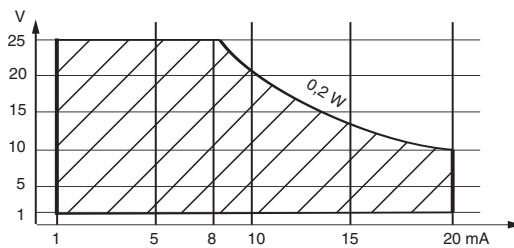

Switching power: 0.2 W
Max. voltage: 25 V
Min. voltage: 1 V
Max. switching current: 20 mA
Min. switching current: 1 mA



Third Angle Projection
Dimensions are shown: Inch (mm)
Specifications and dimensions subject to change



Rotary